



CO₂ Room Sensor in the BAPI-Stat 3 Enclosure with Common Ground Configuration

Installation and Operating Instructions

26141_ins_room_CO2

rev. 04/27/18

Identification and Overview

The BAPI CO₂ Sensor is an accurate and reliable way of incorporating demand controlled ventilation into a building's HVAC strategy. It measures the CO₂ in a range of 0 to 2,000 ppm with a field selectable output of 0 to 5 or 0 to 10 VDC.

The non-dispersive infrared (NDIR) technology has been optimized to reduce drift. The sensor is also altitude compensated for long-term accuracy and stability. Changing air pressure, due to altitude or weather patterns, can change the output of most CO₂ sensors by as much as 17%. The BAPI unit has a built-in barometric sensor that continuously compensates the output for accurate readings despite inclement weather or the altitude of the installation.

The unit can be ordered as CO₂ alone, or with optional temperature sensing, temperature setpoint, occupant override and humidity sensing. The large format display is easy to read and alternates between the measured values (CO₂, Temperature or Humidity). The display is also field adjustable between °F or °C and all the displayed values may be turned on or off by an HVAC technician.

Optional indication of the CO₂ level as "Good, Fair or Poor" is available as a three-color LED on the unit or as an arrow on the display.

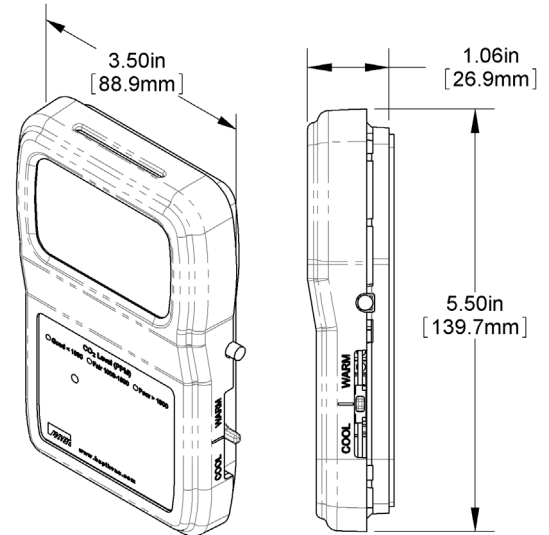

Fig. 1: BAPI-Stat 3 Room CO₂ Sensor

Specifications

Power for 0 to 5 VDC Outputs:

9 to 35 VDC @ 240mA (9 to 24 VDC recommended)

Power for 0 to 10 VDC Outputs:

15 to 35 VDC @ 240mA (15 to 24 VDC recommended)

Sensing Elements:

CO₂ – Single Beam Non-Dispersive Infrared (NDIR) or Dual Channel NDIR for "24/7" Model

Humidity – Capacitive Polymer ±2% RH Accuracy

Temperature Sensor:

Thermistor, RTD or Semiconductor

Operating Environment:

32 to 122°F (0 to 50°C)

0 to 95%, RH non-condensing

Material ABS Plastic, Material Rated UL94V-O

CO₂ Detection Range: 0 – 2000 ppm

Start-Up Time: <2 Minutes

Response Time:

<2 Minutes for 90% step change typical (after start-up)

Mounting: 2"x4" J-Box or drywall – screws provided

Override Output:

Contact.... SPST, 24V AC/DC, 0.5A max

Sensor..... Shorts Out direct temperature sensor

Setpoint... Contact in parallel, resistive setpoint only

LCD Display:

Main Display: 0.76" 4-digit Numeric Values

Minor Display: 0.34" 3-digit Alpha-Numeric (PPM, %RH, °F, °C)

Occupancy BAPI Man Icon: (Blk=Occupied)

Measurement Offsets: (Field Adjustable)

±5° (F or C) in 0.1° increments

±5% RH in 0.1% RH increments

CO₂ Accuracy:

(Single Channel Automatic Background Calibration model)

400 to 1,250 ppm: ±30ppm or 3% of reading, whichever is greater

1,250 to 2,000 ppm: ±5% of reading + 30ppm

CO₂ Accuracy: ("24/7" Dual Channel Model)

75ppm or 10% of reading (whichever is greater)

CO₂ Drift Stability (Dual Channel DCD "24/7" Units):

<5% of full scale over life of product.

LED CO₂ Level Indicator:

Good, Green < 1,000 PPM

Fair, Orange = 1,000 to 1,500 PPM

Poor, Red > 1,500 PPM

Certifications: RoHS

Warranty Period: 5 Years from manufacture date

Specifications subject to change without notice.



CO₂ Room Sensor in the BAPI-Stat 3 Enclosure with Common Ground Configuration

Installation and Operating Instructions

Mounting

Mounting hardware is provided for both junction box and drywall installation (junction box installation shown).

Note: Screw the 1/26" Allen lock-down screw into the base to open the case, less chance of losing it this way. Back out the lock-down screw to secure the cover.

Junction Box

1. Pull the wire through the wall and out of the junction box, leaving about six inches free.
2. Pull the wire through the hole in the base plate.
3. Secure the plate to the box using the #6-32 x 5/8 inch mounting screws provided.
4. Terminate the unit according to the guidelines in the Termination section. (page 3)
5. Mold the foam on the unit's base to the wire bundle to prevent drafts. (see note below)
6. Attach Cover by latching it to the top of the base, rotating the cover down and snapping it into place.
7. Secure the cover by backing out the lock-down screw using a 1/16" Allen wrench until it is flush with the bottom of the cover.

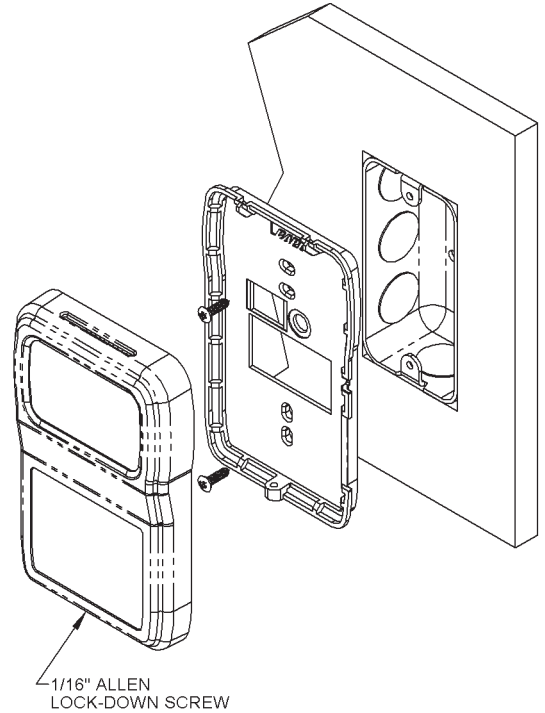

Fig. 2: Mounting to a Junction Box

Drywall Mounting

1. Place the base plate against the wall where you want to mount the sensor.
2. Using a pencil, mark out the two mounting holes and the area where the wires will come through the wall.
3. Drill two 3/16" holes in the center of each marked mounting hole, DO NOT punch the holes or the drywall anchors will not hold. Insert a drywall anchor into each hole.
4. Drill one 1/2" hole in the middle of the marked wiring area.
5. Pull the wire through the wall and out of the 1/2" hole, leaving about six inches free.
6. Pull the wire through the hole in the base plate.
7. Secure the base to the drywall anchors using the #6 x 1 inch mounting screws provided.
8. Terminate the unit according to the guidelines in the Termination section. (page 3)
9. Mold the foam on the unit's base to the wire bundle to prevent drafts. (see note below)
10. Attach cover by latching it to the top of the base, rotating the cover down and snapping it into place.
11. Secure the cover by backing out the lock-down screw using a 1/16" Allen wrench until it is flush with the bottom of the cover.

NOTE: In any wall-mount application, the wall temperature and the temperature of the air within the wall cavity can cause erroneous readings. The mixing of room air and air from within the wall cavity can lead to condensation, erroneous readings and sensor failure. To prevent these conditions, BAPI recommends sealing the conduit leading to the junction box, filling the junction box with fiberglass insulation or sealing the wall cavity.



CO₂ Room Sensor in the BAPI-Stat 3 Enclosure with Common Ground Configuration

Installation and Operating Instructions

26141_ins_room_CO2

rev. 04/27/18

Termination

BAPI recommends using twisted pair of at least 22AWG and sealant filled connectors for all wire connections. Larger gauge wire may be required for long runs. All wiring must comply with the National Electric Code (NEC) and local codes. Do NOT run this device's wiring in the same conduit as AC power wiring. BAPI's tests show fluctuating and inaccurate signals are possible when AC power wiring is in the same conduit as the signal lines. If you are experiencing any of these difficulties, please contact your BAPI representative.



BAPI recommends wiring the product with power disconnected. Proper supply voltage, polarity and wiring connections are important to a successful installation. Not observing these recommendations may damage the product and void the warranty.

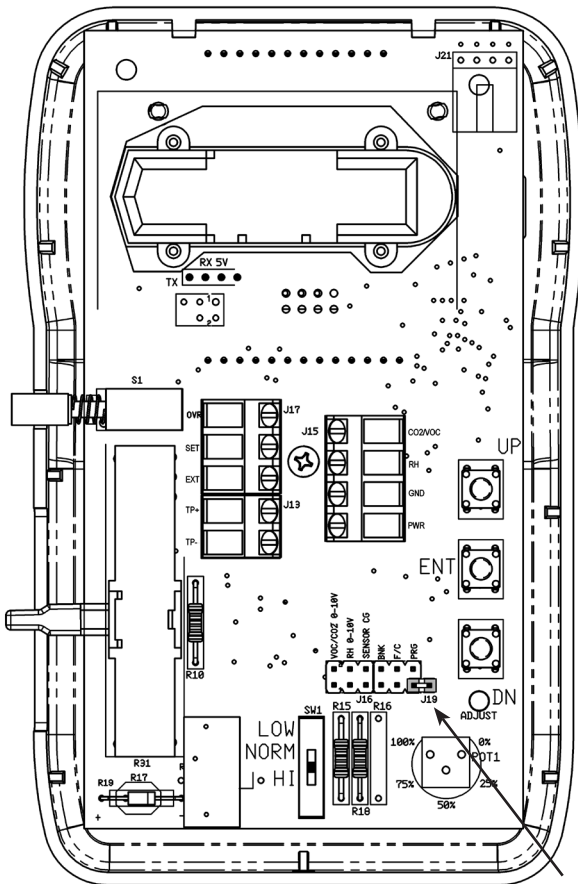

Fig. 3: Circuit Board

Terminal Function

- OVR**..... Override Output (Dry Contact Switch). When Override switch is pushed this terminal is connected to the GND terminal.
- SET**..... Setpoint output. Referenced to GND terminal.
- EXT**..... External occupied LCD indicator is activated by logic LOW or ground at this terminal, referenced to the GND terminal.
- TP+ & TP-** ... Temperature Sensor Output (Resistive Output). When a jumper is on J16, TP- is connected to the GND terminal. When the jumper is off of J16, the temperature sensor is floating. (Semiconductor TP+ = +, TP- = -)
- CO₂/ VOC**.... Voltage output CO₂ Signal (0 to 2,000 ppm) referenced to the GND terminal.
- RH** Voltage output Humidity Signal referenced to the GND terminal.
- GND**..... To controller Ground [GND or Common]
- PWR** Power, referenced to GND
 9 to 35 VDC @ 240mA
 (9 to 24 VDC recommended) for 0 to 5 VDC Outputs
 15 to 35 VDC @ 240mA
 (15 to 24 VDC recommended) for 0 to 10 VDC Outputs

Note: For proper operation, the jumper on PRG connector of J19 must be connected by only one leg.

Note: Unit is not ready for operation until the 10 minute start-up time has elapsed.

POWERING WITH A BAPI VC350A VOLTAGE CONVERTER

The CO₂ unit requires 240mA of current to operate correctly. If this is more current than can be provided by the controller power output, then the unit can be powered by a BAPI VC350A or VC350A-EZ Voltage Converter.

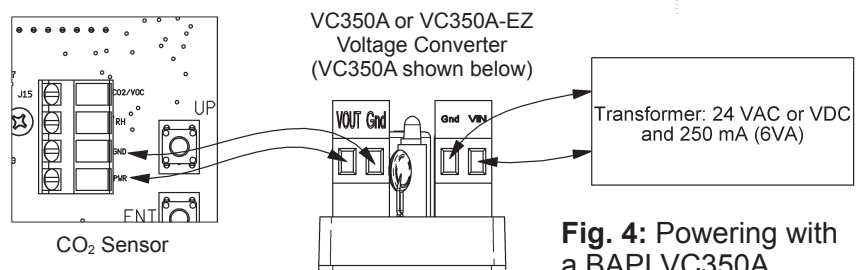

Fig. 4: Powering with a BAPI VC350A

Specifications subject to change without notice.



CO₂ Room Sensor in the BAPI-Stat 3 Enclosure with Common Ground Configuration

Installation and Operating Instructions

26141_ins_room_CO2

rev. 04/27/18

Optional Test and Balance Switch (SW1)

| | |
|--|------------------------------------|
| | Low: Will set sensor value low |
| | Norm: Sensor will operate normally |
| | High: Will set sensor value High |

| Sensor Type | Low Temp | High Temp |
|-----------------------|------------------|-------------------|
| 1000 Ω RTD | 1.02K Ω (41.2°F) | 1.15K Ω (101.5°F) |
| 3000 Ω Thermistor | 7.87K Ω (39.8°F) | 1.50K Ω (106.8°F) |
| 10K-2 Thermistor | 30.1K Ω (34.9°F) | 4.75K Ω (109.1°F) |
| 10K-3 Thermistor | 26.7K Ω (35.9°F) | 5.11K Ω (108.4°F) |
| 10K-3(11K) Thermistor | 7.32K Ω (43.7°F) | 3.65K Ω (105.2°F) |

Optional Communications Jack Wiring

C35 Communication Jack (Male jack shown for clarity)

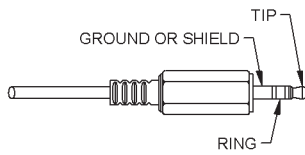

| | Wire Color |
|--------|------------|
| Ground | Black |
| Tip | White |
| Ring | Red |

C11 Communication Jack

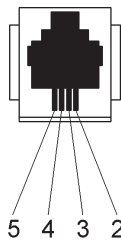

| Comm Jack Pin | Wire Color |
|---------------|---------------|
| 1 | Not Connected |
| 2 | Black |
| 3 | Red |
| 4 | Yellow |
| 5 | Green |
| 6 | Not Connected |

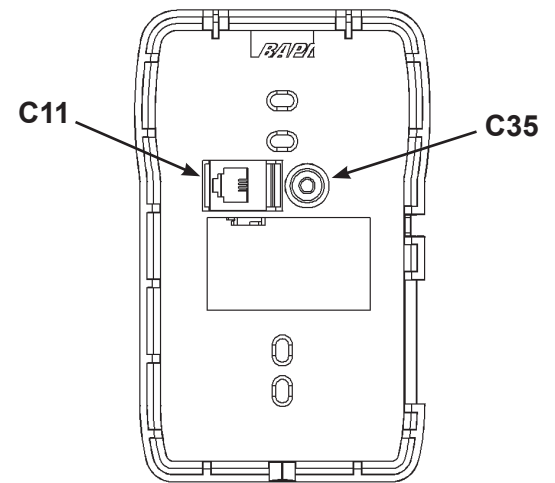

Fig. 5: Communication Jack Locations

User Operation

The display indicates CO₂ in PPM, temperature in °F or °C, %RH, temperature setpoint in degrees °F or °C and override using the BAPI Man icon. The three triangle icons are used with the -ARW option to show CO₂ levels.

The main display indicates the numeric value of the quantity being displayed. The minor display indicates the engineering units of the value, such as PPM, °F, °C or %RH.

Temperature Setpoint Slidepot: Moving the slidepot enough to change the setpoint by one degree will display the setpoint on the main LCD display if equipped with display. The setpoint display will hold for five seconds after moving the slide pot.

Override Button: When the override button is pressed on display units, the BAPI Man icon will display. A dry resistance of less than 1 ohm appears from the override output (OVR) to the Ground terminal (GND). Latching the Icon to show that the system is in override requires that a dry contact on your controller be used to connect terminal EXT to ground.

Optional CO₂ Level Indication via Arrow or 3-Color LED
CO₂ level indication is available via a black arrow on the display or a three-color LED on the logo plate with green for good, yellow for fair and red for poor.

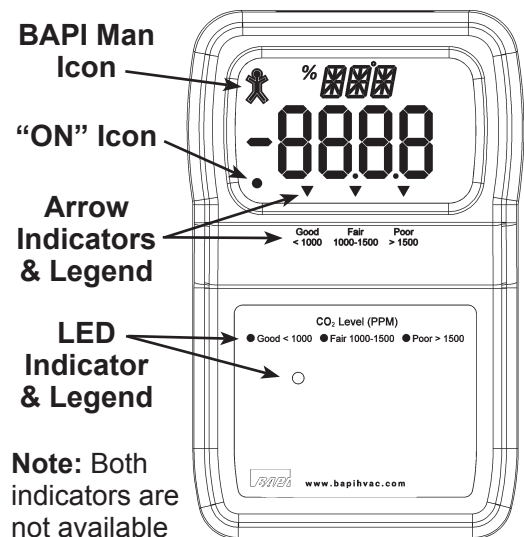

Note: Both indicators are not available together

Fig. 6: CO₂ Unit Indicators (Shown above with all optional indicators)

Specifications subject to change without notice.



CO₂ Room Sensor in the BAPI-Stat 3 Enclosure with Common Ground Configuration

Installation and Operating Instructions

26141_ins_room_CO2

rev. 04/27/18

Optional Technician Adjustments

BAPI's CO₂ room sensor comes calibrated and ready to operate. In some installations the sensor may not match local instrumentation. The technician adjustment procedure allows °F or °C display units, temperature or humidity offsets or display information to be changed at any time.

Removing Ground from Temperature Sensor

Some installations may experience erratic temperature readings. A possible remedy may be to float the temperature sensor as shown in Figs 7 and 8. Run wires directly from TP+ and TP- to the controller's analog input. The VOC/CO₂ and RH jumpers are omitted for clarity.

°F or °C Display Units

Figs 9 and figure 10 show the jumper positions for displayed values of Celsius or Fahrenheit degrees. The jumpers on pins PRG and BNK are omitted for clarity.

Parameter Offsets & Display Information

Figs 11 and 12 show how to place the unit into field setup mode. Take the jumper from the BNK terminals and place it on the PRG terminals. The F/C jumper is omitted for clarity.

The major display should read P1 and the minor display should read DSP.

Use the UP/DN buttons (See Fig 13) to select the desired page.

Press and release the ENT button to select the desired page.

Use the UP/DN buttons to adjust the desired value

Press and release the ENT button to save the change and return to the page display.

Adjust another page or place the jumper into normal operation.

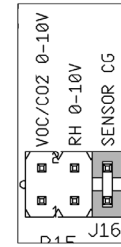

Fig. 7: Temp. Sensor Grounded

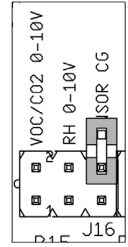

Fig. 8: Temp. Sensor Floating

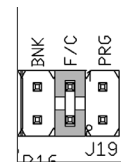

Fig. 9: °F

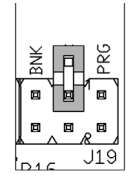

Fig. 10: °C



Fig. 11: Normal Operation

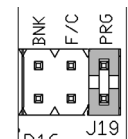

Fig. 12: Programming Setup

| Table 4: Parameter Offsets & Display Information | | | | |
|--|---------|-------|---|---|
| Parameter | Display | | Adjustment | |
| | Main | Minor | Item | Display Action |
| Display Options | P1 | DSP | 1 | Temperature Only |
| | | | 2 | % RH Only |
| | | | 3 | CO ₂ Only |
| | | | 4 | Temperature and %RH (10 second rotation) |
| | | | 5 | Temperature and CO ₂ (10 second rotation) |
| | | | 6 | %RH and CO ₂ (10 second rotation) |
| | | | 7 | Temperature, %RH and CO ₂ (10 second rotation) |
| | | | 8 | Setpoint Display Only |
| Temperature Offset | P2 | TMP | ±5° in 0.1° increments | |
| %RH Offset | P3 | %RH | ±5% RH in 0.1% RH increments | |
| CO ₂ Offset | P4 | CO2 | ±100 ppm in 1 ppm increments | |
| Altitude | P5 | ALT | Effective Pressure Altitude (display only, no adjustment) | |

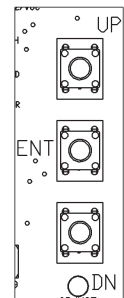

Fig. 13: Calibration Buttons

Specifications subject to change without notice.



CO₂ Room Sensor in the BAPI-Stat 3 Enclosure with Common Ground Configuration

Installation and Operating Instructions

26141_ins_room_CO2

rev. 04/27/18

Output Selection

The CO₂ outputs may be field configured for 0 to 5 VDC or 0 to 10 VDC outputs at any time. Set the jumpers on J16 as shown in Figs 12 and 13.

The humidity outputs may be field configured for 0 to 5, 1 to 5, 0 to 10 or 2 to 10 VDC outputs at any time. Set the jumpers on J16 as shown in Figs 14 and 15.

Note: The jumpers on the pins not being described are omitted for clarity on the figures at right.

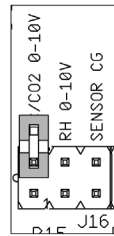

Fig. 14:
CO₂ Output
0 to 5 VDC

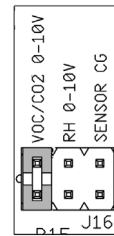

Fig. 15: CO₂
Output 0 to
10 VDC

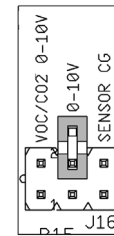

Fig. 16: %RH
Output 0 to 5
or 1 to 5 VDC

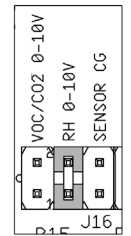

Fig. 17: %RH
Output 0 to 10
or 2 to 10 VDC

Diagnostics

Possible Problems:

Possible Solutions:

General troubleshooting

Determine that the input is set up correctly in the controller's and building automation software. Check wiring at the sensor and controller for proper connections. If there is corrosion, clean off the corrosion, re-strip the interconnecting wire and reapply the connection. In extreme cases, replace the controller, interconnecting wire and/or sensor.

Label the terminals that the interconnecting wires are connected to at the sensor end and the controller end. Disconnect the interconnecting wires from the controller and the sensor. With the interconnecting wires separated at both ends measure the resistance from wire-to-wire with a multimeter. The meter should read greater than 10 Meg-ohms, open or OL depending on the meter you have. Short the interconnecting wires together at one end. Go to the other end and measure the resistance from wire-to-wire with a multimeter. The meter should read less than 10 ohms (22 gauge or larger, 250 feet or less). If either test fails, replace the wire.

Check power supply/controller voltage supply for proper voltage (see specifications)

Incorrect CO₂

Wait 15 minutes after a power interruption.

Check all software parameters

Determine if the sensor is exposed to an external environment different from the room (conduit draft)

If the sensor is reading consistently high, make sure that the power supply to the unit can provide 240mA. A low power situation will cause high CO₂ readings.

Note: If the CO₂ sensor has consistently given high PPM readings for over 5 days, it will take up to 14 days for the readings to return to normal.

Incorrect Humidity

Check all software parameters

If available, check the sensor against a calibrated instrument such as a hygrometer

Determine if the sensor is exposed to an external environment different from the room (conduit draft)

Incorrect Temperature

Check the wires at the sensor and controller for proper connections.

Check the Temperature Output of the unit. Disconnect the temperature sensor's wire (Terminals TP+ & TP-) and measure the temperature sensor's resistance across the sensor output pins with an ohmmeter. Put the ohmmeter's black lead on Terminal TP- and the red lead on Terminal TP+. Compare the temperature sensor's resistance to the appropriate temperature sensor table on the BAPI website. (Go to www.bapihvac.com; click on "Resource Library" and "Sensor Specs", then click on the sensor type you have.) If the measured resistance differs from the temperature table by more than 5%, call BAPI technical support.

Determine if the sensor is exposed to an external environment different from the room (conduit or wall cavity draft)

Specifications subject to change without notice.